



Important Instructions to examiners

- 1) The answers should be examined by key words and not as word-to-word as given in the model answer scheme.
- 2) The model answer and the answer written by candidate may vary but the examiner may try to assess the understanding level of the candidate.
- 3) The language errors such as grammatical, spelling errors should not be given more importance. (Not applicable for subject English and Communication Skills.)
- 4) While assessing figures, examiner may give credit for principal components indicated in the figure. The figures drawn by the candidate and those in the model answer may vary. The examiner may give credit for any equivalent figure drawn.
- 5) Credits may be given step wise for numerical problems. In some cases, the assumed constant values may vary and there may be some difference in the candidate's answers and the model answer.
- 6) In case of some questions credit may be given by judgment on part of examiner of relevant answer based on candidate's understanding.
- 7) For programming language papers, credit may be given to any other program based on equivalent concept.

Que. No.	Sub. Que.	Model Answers	Marks	Total Marks
Q. 1	(A)	Attempt any <u>FIVE</u> of the following :		10
	a) Ans.	List four physical properties of OPC. <u>Physical properties of OPC:</u> i. Fineness ii. Standard consistency or Normal consistency iii. Initial and Final setting time iv. Soundness v. Compressive Strength	$\frac{1}{2}$ each (any four)	2
	b) Ans.	Define bulking of sand. Bulking of sand is defined as increase in volume of given sand due to surface moisture present on surface of particles.	2	2
	c) Ans.	State Duff Abraham's water cement ratio law. Duff Abraham's Law: For workable concrete, the compressive strength of concrete depends only on water-cement ratio.	2	2
d) Ans.	Name four methods of concrete mix design. i. Arbitrary proportion method ii. Maximum density method iii. Fineness modulus method iv. ACI Committee 211 method v. Road note no. 4 method (Grading Curve Method) vi. Indian road congress method (IRC - 44) vii. High strength concrete mix design method viii. Indian Standard method (IS 10262: 2009) ix. Trial and error method x. Surface area method	$\frac{1}{2}$ each (any four)	2	



Que. No.	Sub. Que.	Model Answers	Marks	Total Marks
Q.1		<p>xi. Mix design based on flexural strength</p> <p>xii. 12.British DOE mix design method (Department of Environment)</p>		
	e) Ans.	<p>In sequence, write concreting operations.</p> <p>i. Batching of materials</p> <p>ii. Mixing of materials</p> <p>iii. Transportation of concrete</p> <p>iv. Placing of concrete</p> <p>v. Compaction of concrete</p> <p>vi. Curing of concrete</p> <p>vii. Finishing of concrete</p>	2	2
	f) Ans.	<p>State two purposes of using accelerating admixtures in the concrete.</p> <p>i. To accelerate the initial setting of concrete</p> <p>ii. Permit early removal of formwork in cold climate.</p> <p>iii. Reduce the required period of curing</p> <p>iv. Speed of the work can be boosted by early removal of formwork</p>	1 each (any two)	2
	g) Ans.	<p>State two uses of low heat cement.</p> <p>i. It is used for mass concrete works such as dams.</p> <p>ii. It is used for cracks resistant structures.</p> <p>iii. It is used for sulphate resistant structures.</p> <p>iv. It used in concreting of nuclear power plant, sea walts, break waters, etc.</p>	1 each (any two)	2
Q.2		<p>Attempt any <u>THREE</u> of the following :</p>		12
	a) Ans.	<p>Explain the method to determine initial and final setting time of cement.</p> <p>Procedure:</p> <p>i. Take 400 gm. of cement sample and add 0.85 times water required for its standard consistency to prepare homogenous cement paste. Note down the time at which water is added to cement as T₁ min.</p> <p>ii. Fill this cement paste in Vicat's mould. Keep this mould under Vicat's apparatus with IST needle attached to it.</p> <p>iii. Now allow the IST needle to penetrate in the paste by realize pin observe the total penetration. If the penetration is not 33</p>	4	4



Que. No.	Sub. Que.	Model Answers	Marks	Total Marks															
Q.2		<p>to 35 mm from top then change the position of penetration surface.</p> <p>iv. Note down the time at which IST needle will give required penetration as T_2 min. Hence calculate the initial setting time.</p> <p>v. $IST = T_2 - T_1$ min.</p> <p>vi. Replace IST needle with FST needle and allow FST needle to penetrate in same cement paste.</p> <p>vii. Note down the time at which FST needle will give the Just impression on a cement surface as T_3 min.</p> <p>viii. Calculate final setting time i.e. $FST = T_3 - T_1$ min.</p>																	
	b) Ans.	<p>Classify the aggregate based on its size and shape. Classification of aggregate according to Size: As per size aggregates are divided into two categories:</p> <p>i. Coarse Aggregate: The aggregate having size bigger than 4.75mm is considered as coarse aggregate.</p> <p>ii. Fine Aggregate: The aggregate whose size is 4.75mm and less is considered as fine aggregate.</p> <p>Classification of aggregate according to shape: As per shape aggregates are divided into four categories:</p> <p>i. Rounded: This type of aggregate is completely shaped by attrition or water worn.</p> <p>ii. Irregular or partly rounded: This type of aggregate is naturally irregular or partly shaped by attrition.</p> <p>iii. Angular: This type of aggregate contains well defined edges formed at intersection of roughly planer faces.</p> <p>iv. Flaky and elongated: This type of aggregate having small thickness as compared to width or length.</p>	2	4															
	c)	<p>Calculate the average crushing value of aggregate using following data and write its suitability.</p> <table border="1"> <thead> <tr> <th>Sr. No.</th> <th>Description</th> <th>A</th> <th>B</th> <th>C</th> </tr> </thead> <tbody> <tr> <td>1</td> <td>Weight of oven dried sample</td> <td>3119</td> <td>3246</td> <td>3184</td> </tr> <tr> <td>2</td> <td>Weight of fraction passing 2.36mm I.S. Sieve</td> <td>575</td> <td>581</td> <td>598</td> </tr> </tbody> </table>	Sr. No.	Description	A	B	C	1	Weight of oven dried sample	3119	3246	3184	2	Weight of fraction passing 2.36mm I.S. Sieve	575	581	598	2	
Sr. No.	Description	A	B	C															
1	Weight of oven dried sample	3119	3246	3184															
2	Weight of fraction passing 2.36mm I.S. Sieve	575	581	598															
	Ans.	<p>To find aggregate crushing value,</p> <p>$\%ACV = \frac{\text{Weight of agg. passing through 2.36mm IS sieve} \times 100}{\text{Weight of oven dried aggregate}}$</p>																	



Que. No.	Sub. Que.	Model Answers	Marks	Total Marks
Q.2		<p>For observation I: $\%ACV = (575/3119) \times 100 = 18.43\%$</p> <p>For observation II: $\%ACV = (581/3246) \times 100 = 17.89\%$</p> <p>For observation III: $\%ACV = (598/3184) \times 100 = 18.78\%$</p> <p>To find average crushing value of given aggregate $Average \%ACV = (18.43 + 17.89 + 18.78) / 3$</p> <p>Average %ACV = 18.36%</p> <p>Suitability: As the % ACV is 18.36%, which is less than 30%, hence the given sample of aggregate is suitable for non-wearing surfaces like roadways, runways etc.</p> <p>d) A sand sample has a fineness modulus of 1.95. Whether this sand can be used for concreting? Explain the procedure to bring the fineness modulus in required permissible limits. State its importance.</p>	3	4
Ans.		<p>The given sand sample has a fineness modulus 1.95, which is less than prescribed limit i.e. 2.2-3.2. It indicates that sand particles are finer, which is not suitable for satisfactory concreting work.</p> <p>Procedure to bring FM in prescribed limits:</p> <ol style="list-style-type: none">The cumulative % retained of tested sand sample should be increased by adding sand particles which are having lesser % retained in the calculation.When quantity of such sand particles are increased, then FM of sand will be in the above mentioned range, which is also considered as well graded sand sample. <p>Importance of FM:</p> <ol style="list-style-type: none">Fineness modulus of sand should be 2.2 to 2.6 for fine sand, which is helpful for minimizing voids ratio and increasing density of concrete mass.Well graded sand is also useful for good bonding of particles and related strength criteria of concrete.	1	4



Que. No.	Sub. Que.	Model Answers	Marks	Total Marks															
Q.3	a)	<p>Attempt any <u>THREE</u> of the following :</p> <p>Suggest the compaction factor for the following degree of workability.</p> <table border="1"><thead><tr><th>Sr. No.</th><th>Degree of workability</th><th>Compaction factor</th></tr></thead><tbody><tr><td>i</td><td>Medium</td><td>0.92</td></tr><tr><td>ii</td><td>High</td><td>0.95</td></tr><tr><td>iii</td><td>Very low</td><td>0.78</td></tr><tr><td>iv</td><td>Low</td><td>0.85</td></tr></tbody></table>	Sr. No.	Degree of workability	Compaction factor	i	Medium	0.92	ii	High	0.95	iii	Very low	0.78	iv	Low	0.85	1 each	4
Sr. No.	Degree of workability	Compaction factor																	
i	Medium	0.92																	
ii	High	0.95																	
iii	Very low	0.78																	
iv	Low	0.85																	
	b)	<p>Illustrate the effect of properties of coarse aggregates on compressive strength of concrete.</p> <p>Effect of properties of coarse aggregates on compressive strength of concrete.</p> <p>i. Size of aggregate:</p> <p>If coarse aggregate particles are of large size (say 20 mm) in concrete mixture , then concrete becomes harsh and only strength may reduce due to honey combing. But if coarse aggregate are of smaller sizes only (say 10 mm). Then ultimate strength of concrete will be lesser. Therefore coarse aggregate with combination of both sizes (i.e. 10 and 20 mm) will give better workable concrete and more compressive strength.</p> <p>ii. Shape of aggregate:</p> <p>If shape of concrete aggregate is angular then there is good interlocking of aggregate particles. Hence it gives more compressive strength. If shape of coarse aggregate is sub angular or sub rounded then compressive strength reduces due to less bonding between particles.</p> <p>iii. Surface texture:</p> <p>If the texture of coarse aggregate is rough then aggregate gets interlocked strongly than smooth textured aggregates in presence of same cement slurry.</p>	1 each (any four)	4															



Que. No.	Sub. Que.	Model Answers	Marks	Total Marks															
Q.3		<p>iv. Water absorption:</p> <p>If the % water absorption of coarse aggregate is more than prescribed limit, then concrete becomes harsh result in reduction of strength. But if water absorption is less concrete becomes as per proportion giving required strength.</p> <p><i>(Note: Other than above mentioned properties of coarse aggregate should be considered).</i></p>																	
	c)	<p>Explain the procedure for measurement of workability of fresh concrete using slump cone test.</p>																	
	Ans.	<p>Test Procedure:</p> <ol style="list-style-type: none">Clean the mould from inside and apply oil to it.Place the mould on smooth horizontal, rigid & non-absorbent surface or the centre of metallic tray.Fill the mould with the concrete to be tested in four layers, tamping each layer 25 times with the tamping rod, taking care that the strokes are evenly distributed over the c/s.Remove the mould by one smooth continuous vertical motion.The concrete subsides and this subsidence is called "slump." Measure the slump in mm by using a metric scale from top of cone.Based on measured slump, the degree of workability is designated as follows.																	
		<table border="1"><thead><tr><th>Sr. No.</th><th>Slump (mm)</th><th>Degree of workability</th></tr></thead><tbody><tr><td>1</td><td>0-25</td><td>Very low</td></tr><tr><td>2</td><td>25-50</td><td>Low</td></tr><tr><td>3</td><td>50-100</td><td>Medium</td></tr><tr><td>4</td><td>100-175</td><td>High</td></tr></tbody></table>	Sr. No.	Slump (mm)	Degree of workability	1	0-25	Very low	2	25-50	Low	3	50-100	Medium	4	100-175	High	4	4
Sr. No.	Slump (mm)	Degree of workability																	
1	0-25	Very low																	
2	25-50	Low																	
3	50-100	Medium																	
4	100-175	High																	
	d)	<p>Explain the necessity of supervision for concreting operations.(any four)</p>																	
	Ans.	<p>Necessity of supervision for concreting operation:</p> <ol style="list-style-type: none">Supervision is necessary to complete all concreting operations in standard manner.It is necessary to avoid any type of delay in concrete work.It is also beneficial to reduce wastage of concrete during concreting.It is required to get overall quality in concrete work at site.Supervision becomes essential in maintaining smooth flow of concreting operations at each stage of project.It found very effective in controlling bad workmanship.	1 each (any four)	4															



Que. No.	Sub. Que.	Model Answers	Marks	Total Marks
Q.4		Attempt any <u>THREE</u> of the following:		12
	a)	Explain the importance of water/cement ratio in the concrete mix. Importance of water/cement ratio in the concrete mix : i. The W/C ratio plays very vital role in concrete mixture. The improper or random selection of W/C ratio leads in various defects in fresh and hardened concrete. ii. If W/C ratio is less (say $w/c = 1/4 = 0.25$), then concrete will become harsh and results in honeycombing or porous nature due to poor workability. iii. If w/c ratio is more (say $w/c = 3/4 = 0.75$), then concrete undergoes segregation and bleeding. Thus finally concrete shows defects in it. iv. Therefore w/c ratio should be optimum, which depends on grade of concrete and exposure conditions hence w/c ratio should be selected from IS: 456:2000. v. If w/c ratio is opted out properly as mentioned above, then concrete possess good workability, compressive strength and durability ultimately.	1 each (any four)	4
	b)	Write four objectives of concrete mix design. i. To achieve a specified compressive strength of concrete. ii. To reduce wastage of concrete by correct proportioning. iii. To achieve economy by selecting appropriate concrete ingredients. iv. To maintain workability of concrete mix throughout work. v. To obtain maximum possible yield per bag of cement. vi. To ensure less defects and enhanced durability of concrete.	1 each (any four)	4
c)	Describe four characteristics of ready mix concrete. Characteristics of ready mix concrete: i. RMC can be ordered in bulk amount at a time. ii. It has more homogeneity as compared to other concrete. iii. It becomes economical in large project.	1 each (any four)	4	



Que. No.	Sub. Que.	Model Answers	Marks	Total Marks
Q.4		<p>iv. It can be easily transported at a longer distance without setting of concrete.</p> <p>v. Quality of concrete is uniform and high.</p> <p>vi. Useful in urban areas where it is lack of space.</p> <p>vii. No dust and noise pollution.</p>		
	d)	Explain four effects of hot weather on concrete.		
	Ans.	<p>Effects of hot weather on concrete:</p> <p>i. Due to hot weather, concrete shows rapid rate of hardening, which results difficulty in transportation of concrete.</p> <p>ii. Water from concrete mix gets evaporated fastly, which results on w/c ratio and less workability of concrete.</p> <p>iii. Water may get absorbed by formwork, aggregate or ground due to excessive heat.</p> <p>iv. More shrinkage cracks get developed on concrete surface due to incomplete hydration with less water in concrete. Hence, early finishing becomes more essential.</p> <p>v. Continuous curing is required to keep humidity and to avoid further development of cracks.</p> <p>vi. Air entrained in concrete may get expelled due to temperature, hence workability may reduce additionally.</p>	1 each (any four)	4
	e)	Write two advantages and two disadvantages of vacuum de-watered concrete floor.		
	Ans.	<p>Advantages of vacuum de-watered concrete floor:</p> <p>i. It reduces the time for finishing the floor.</p> <p>ii. Smooth and clean finish surface.</p> <p>iii. It reduce permeability and increase durability of concrete floor</p> <p>iv. Increase the strength of concrete. Compressive strength is increased by 10 to 50%.</p> <p>v. Decrease the total shrinkage.</p> <p>Disadvantages of vacuum de-watered concrete floor:</p> <p>i. High initial cost.</p> <p>ii. It required specific equipment.</p>	1 each (any two)	4

Que. No.	Sub. Que.	Model Answers	Marks	Total Marks
Q.5	b)	<p>Explain the rebound hammer test procedure and show the relationship between compressive strength and rebound number with hammer horizontal and vertical on dry and wet surface of concrete.</p> <p>Ans. Rebound Hammer Test:</p> <ol style="list-style-type: none"> i. Initially the plunger of rebound hammer is Kept touching to the target concrete surface ii. Then the tubular casing of hammer is pushed towards concrete, so that the spring gets wind up around the plunger iii. Now release the mass attached to plunger using dash pot, so that hammer will impact on concrete surface and rebound back depending on strength of concrete. iv. Due to backward motion of hammer, pointer on graduated scale will move in same direction. v. Observe the distance travelled by pointer/rider on graduated scale as rebound Number. vi. If this rebound Number is less, the strength of concrete will be less, But if it is more, then concrete possess sufficient strength. 	4	6
			2	

Fig. Relationship between Compressive Strength and Rebound Number

Que. No.	Sub. Que.	Model Answers	Marks	Total Marks
Q.5	c)	<p>Explain the ultrasonic pulse velocity test and techniques of measuring pulse velocity through concrete.</p> <p>Ans.</p> <p>Procedure:</p> <ol style="list-style-type: none"> Ultrasonic pulse velocity method consists of measuring the time travel of an ultrasonic pulse passing through the concrete to be tested. The pulse generated circuit consists of electronic circuit for generating pulses and a transducer for transforming these electronic pulses into mechanical energy having vibration frequency in the range of 15 to 50 kHz. The time travel between the initial path and the reception of the pulse is measured electronically. The path length between transducer divided by the time of travel gives the average velocity of the wave propagation. <p>PUNDIT (Portable Ultrasonic Non Destructive Digital Indicating Tester) is a battery operated fully digitized instrument which is generally used for measuring ultrasonic pulse velocity.</p> <p>Techniques of measuring Pulse velocity through concrete :</p> <ol style="list-style-type: none"> Direct transmission: The transmitting and receiving transducers are placed on opposite surfaces of the concrete slab. This will give maximum sensitivity and provide a well-defined path length 	3	
		<p>Indirect transmission: The transmitting and receiving transducers are placed on adjacent surfaces of the concrete slab.</p>	1	6
		<p>Semi-direct transmission: The transmitting and receiving transducers are placed on adjacent surfaces of the concrete slab.</p>	1	

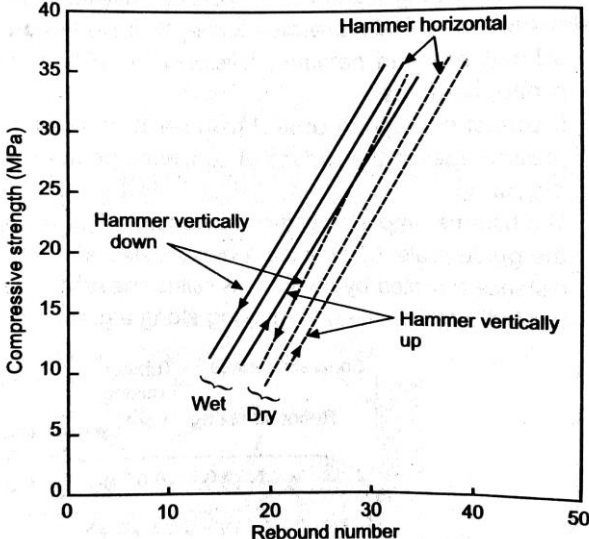
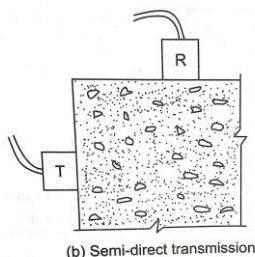
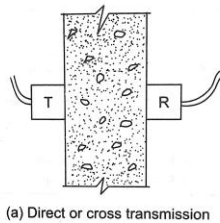
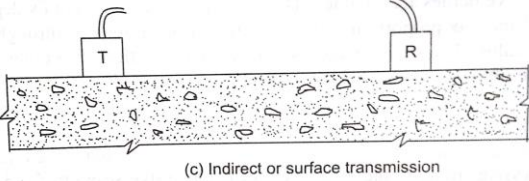
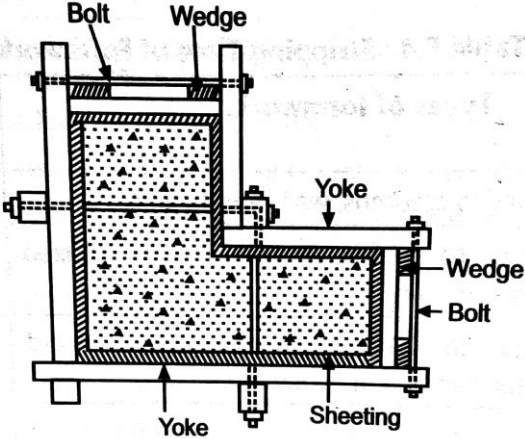

Que. No.	Sub. Que.	Model Answers	Marks	Total Marks
Q.5		<p>c) Surface transmission: The transmitting and receiving transducers are placed on same surfaces of the concrete slab</p>  <p>(c) Indirect or surface transmission</p>	1	
Q.6	<p>a) Write four requirements of good formwork and draw a sketch showing cross section of formwork for a L-shaped column.</p> <p>Ans.</p>	<p>Attempt any TWO of the following:</p> <ol style="list-style-type: none"> It should be strong enough to resist the weight of concrete, workers and machinery. It should be economical compared to total cost of construction. It should be possible to use the formwork for more number of times. It should give smooth finish and shape to concrete faces. It should be possible to erect and dismantle the formwork very easily. It should be easily and locally available. It should be rigid enough to retain its shape without deflection or bulging.  <p>Fig. Cross-Section of L-Shape Column</p>	<p>1 each (any four)</p> <p>2</p>	<p>12</p> <p>6</p>

Que. No.	Sub. Que.	Model Answers	Marks	Total Marks
Q.6	b)	<p>Suggest one type of materials for water proofing for the following situations.</p> <ol style="list-style-type: none"> Rising dampness in building Leakages in dam Concrete continuously in wet or damp condition Leakages in lavatory ,bathroom and kitchen floor Cracks on plastered surface Cracks on roof surface 		
	Ans.	<ol style="list-style-type: none"> Flexible materials like butyl rubber, hot bitumen (asphalt), plastic sheets, bituminous felts, sheets of lead. Liquid applied cementitious membranes Liquid applied cementitious membranes Liquid applied cementitious membranes, liquid applied latex membranes, brick bat coba, liquid applied bituminous membrane. Liquid applied cementitious membranes. Brick bat coba, liquid applied bituminous membrane. 	1 each	6
	c)	<p>Suggest the type of joints in concrete when it is likely to increase in volume due to temperature change. Explain it and draw its neat sketch.</p>		
	Ans.	<p>When it is likely to increase in volume due to temperature change expansion joint is constructed.</p> <ol style="list-style-type: none"> Expansion joints are provided by keeping a gap between panels of concrete and later sealing it The joint which is provided to present the expansion in concrete caused due to thermal stresses. These stresses produce due to extreme temperature conditions. The typical expansion joint is provided with dowel bars at a depth equal to half of slab thickness. This dowel of 20 mm diameter and 550 mm long is covered with metal cap filled with cotton and finally such joint is sealed using sealants like wood, thermocol or bitumen. 	1 3	6
		<p>Expansion Joint with Load-Transfer Device</p> <p>Expansion joint filler → ← 12mm to 25 mm</p> <p>Expansion Joint Without Load-Transfer Device</p>	2	
		<p>Fig. Expansion Joint</p>		